

# Design Guide

Recommendations & Technical Information



 caesarstone®

4033 Rugged Concrete™

2023 Edition



# Caesarstone Design Manual

©2023 Caesarstone Australia Pty Ltd. All rights reserved.

No parts of this work may be reproduced in any form or by any means - graphic, electronic, or mechanical, including photocopying, recording, taping, or information storage and retrieval systems - without written permission from Caesarstone Australia Pty Ltd.

This manual supersedes all previous manuals. Content is subject to change at any time without notice. Caesarstone is a registered trademark of Caesarstone Ltd.

The information and data set forth herein is intended for use by persons having appropriate technical skills and knowledge and for utilisation at their discretion and risk. We accept no responsibility for and disclaim all liability for any dangerous or harmful effects or outcomes that may be caused by the fabrication and installation of our products.

Products referred to in this document may be either, or both, trademarks or registered trademarks of the respective owners. Neither the publisher nor the author claims these trademarks.

## Notice

This document is intended only as general guidance. While taking every precaution in preparing this document, the publisher and the author assume no responsibility for errors or omissions, or damages resulting from the use of the information contained in this document. Under no circumstances shall the publisher and or the author be liable for any loss, damage, loss of profit or any other commercial damage caused or alleged to have been caused directly or indirectly as a result of any person relying upon any information contained in this document.

No guarantee or warranty of any kind, express or implied, is made of merchantability, fitness for a particular purpose or otherwise.

## Trademarks

Caesarstone®, the Caesarstone® logo, Caesarstone® graphics, icons and graphic symbols are registered trademarks and/or service marks of Caesarstone Ltd. Photos or images are copyright and may not be reproduced without written permission. Nothing contained in the Technical Support Manual grants or should be construed as granting, by implication or otherwise, any licence or right to use these marks or to reproduce copyright material, without the express written permission of Caesarstone Ltd and/or Caesarstone Australia Pty Ltd.

Accessing and/or using this Technical Support Manual indicates that you accept these Terms.

©2023 All rights reserved.  
Caesarstone Australia Pty Ltd  
Moorebank Logistic Park  
Warehouse 3A East  
400 Moorebank Avenue  
Moorebank NSW 2170

Telephone: 1300 119 119  
Email: sales@caesarstone.com.au

## About This Manual

Caesarstone product collections are ideal for a wide range of interior commercial and residential applications. Typical applications include kitchen benchtops, bar tops, vanities, interior cladding, reception counters, wall cladding and furniture.

The Caesarstone Outdoor collection are the only surfaces suitable for exterior use.

Caesarstone surfaces are manufactured and available in several product collections, each with unique properties.

This manual intends to provide industry professionals with the latest, most up to date information relevant to designing with and the installation of Caesarstone slabs.

It contains recommendations and technical information about Caesarstone products, and your Stonemason will make the best choice of fabrication and installation methods to suit the use and application of the slabs.

This manual is for general guidance only and not for any other purpose, nor is it legally binding in any way or meant for use in dispute resolution between Caesarstone, a Stonemason or any other party

### **Warranty**

Compliance or Non-Compliance with the recommendations contained in this manual does not affect the warranty as provided by Caesarstone.

Caesarstone's Lifetime Warranty is for the material only and any defects that relate to the production of the Caesarstone slabs. Full details of our warranty are available on the Caesarstone web site at [www.caesarstone.com.au](http://www.caesarstone.com.au)

The slab suitability, work quality, fabrication, installation and application are the responsibility of the Stonemason.

**IMPORTANT.** All applications and installations must be designed and constructed in strict compliance with all relevant regulations and standards.



---

## Table of Contents

Product Information	5
Caesarstone Branding	5
Placement of Joins	6
Under bench Appliances	8
Cooktop Locations	9
Induction Cooktops	9
Overhangs	10
Carcass Rail Support	11
Cantilever Islands	12
Benchttop Cut-outs	13
Cut-out Surrounds	14
Large Cut-outs	14
Cut-out Supports	15
Sink Drainers	17
Sink Cut-Outs	18
Kitchen Splashbacks	19
Where can Caesarstone be used?	19
Installation Guidelines	20
Edge Profiles	21
Preparing the Base Units & Cabinets	23
Cabinet Support	24
Finishing Touches	24
Tabletops	25
Tabletop Frames	25
Vanities	26
Laundry / Kitchen	27
Laundry Tubs	26
Washing Machine & Dryer	28
Heat Resistance	29
Care & Maintenance	30
Cleaning Reference Guide	30

## Product Information

Slab data provided here is nominal only and provided for storage and transportation purposes only. Actual usable slab surface area is slightly less per side on surfaces with a bevelled perimeter.

	Standard	Grande
Length	3050mm +/- 10mm	3240mm +/- 10mm
Width	1440mm +/- 5mm	1640mm +/- 5mm
Thickness	20mm +/- 1.5mm 20mm = 198-206kg (45-47 kg/m <sup>2</sup> )	20mm +/- 1.5mm 20mm = 236-247kg (45-47 kg/m <sup>2</sup> )

All sizes are nominal.

Actual usable slab surface area is slightly less per side.

## Caesarstone Branding

A stamp appears on the back of the slab with identification information. This information remains on the slab for its lifetime and for identification after installation.

CAESARSTONE	201233387	01/01/14	2165603	3200 P
	Slab ID Number	Slab Inspection Date	Batch Number	Colour & Finish Type

Batch Number: This allows you to track multiple slabs of the same batch. Any job requiring multiple slabs must use slabs from the same batch.

Slab ID Number: This number allows you to identify individual slabs and assists in identifying offcuts originating from the same slab.

Note: There is no correlation between the Batch number and the Slab ID. The Inspection date is not the date of manufacture.

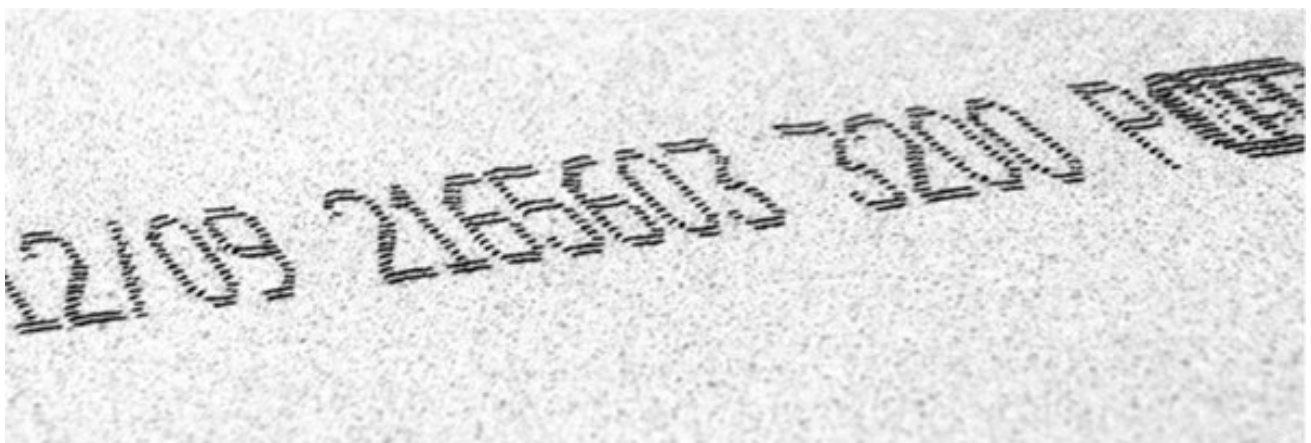

## Placement of Joins

When designing benchtops using Caesarstone slabs, joins are recommended at every change of direction in a benchtop to ensure there are no L-shaped cut-outs.

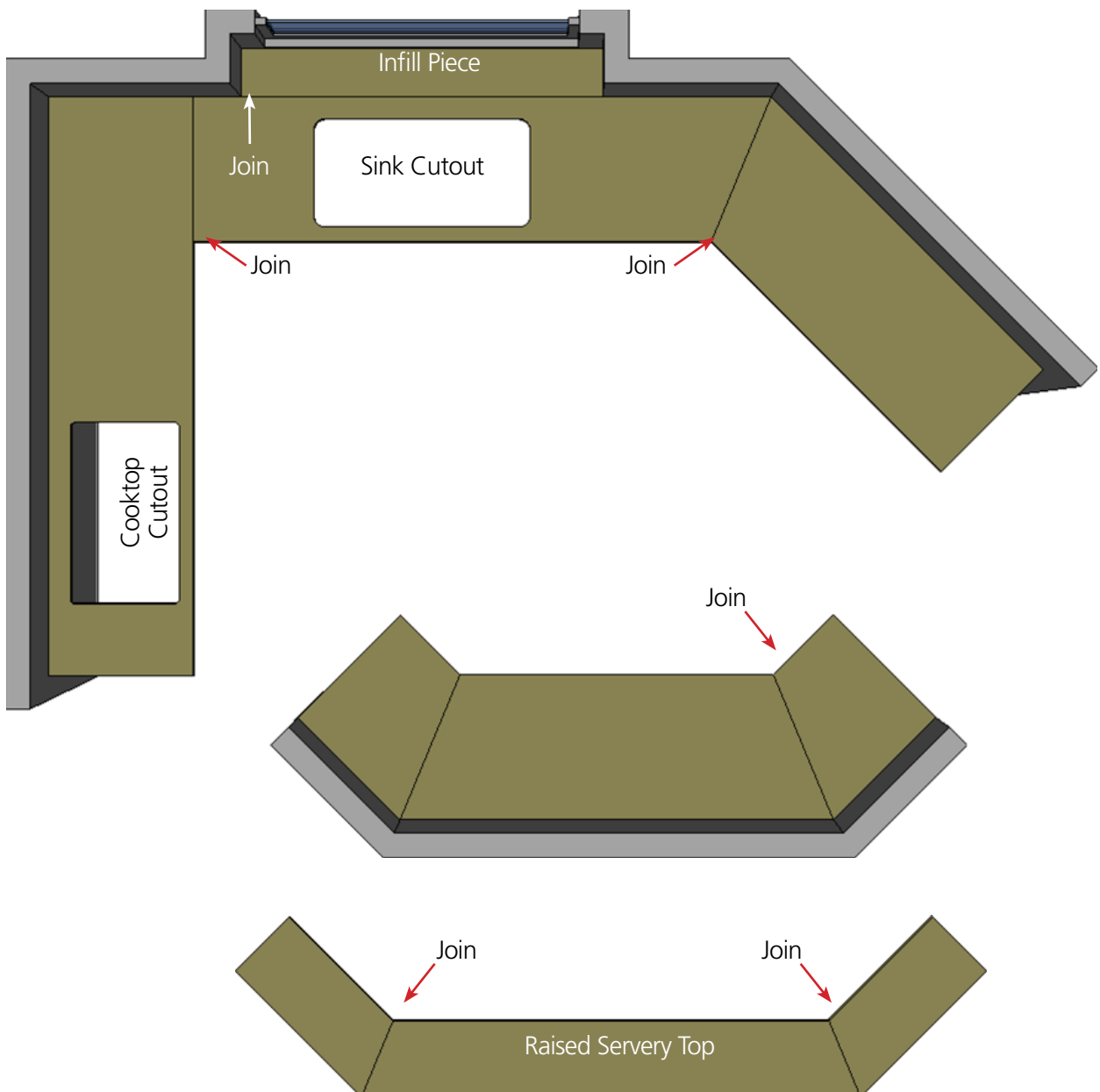

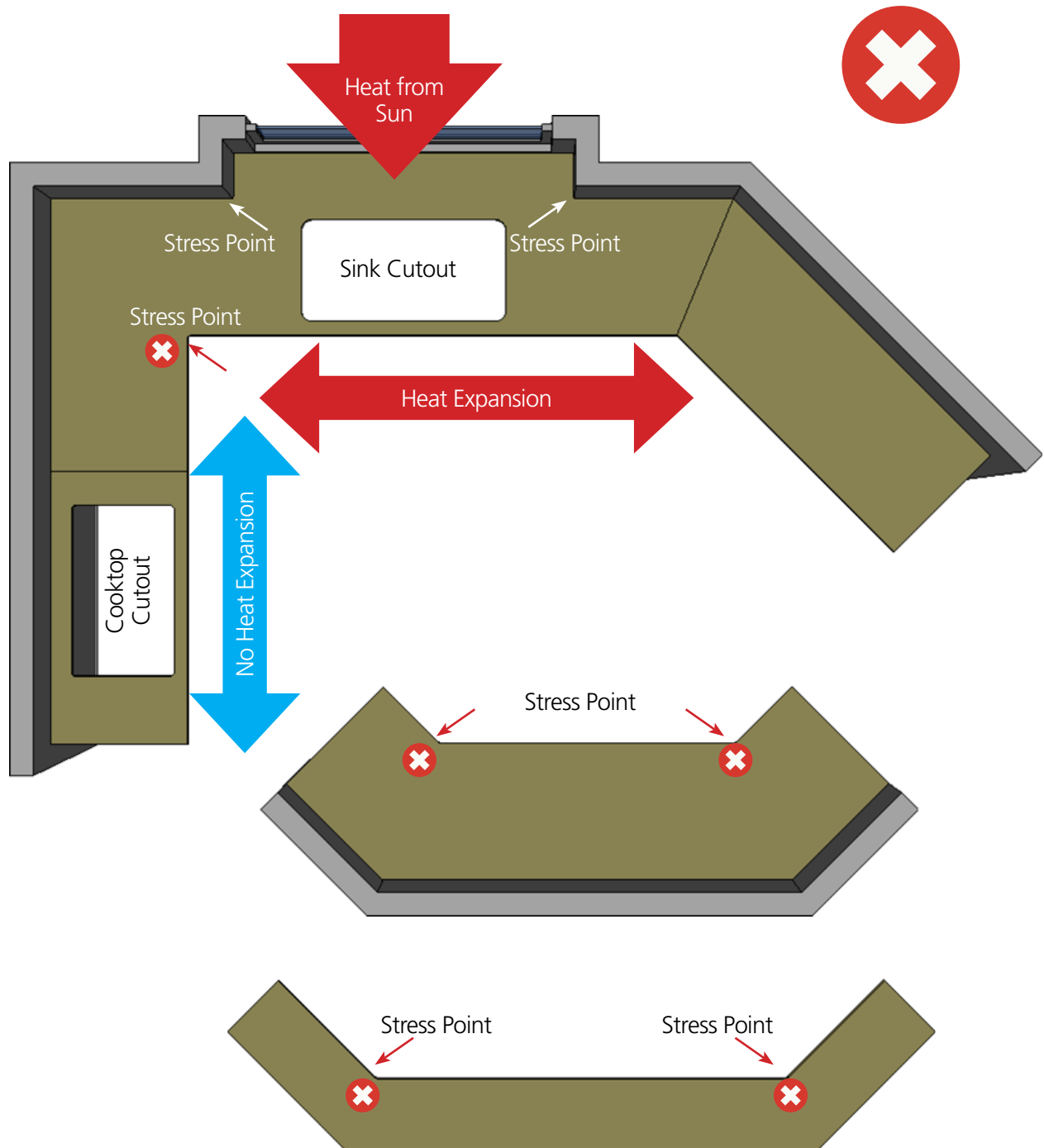

Although possible to cut the benchtops pictured as one piece from a slab, we do not recommend it; it is essential to consider the risks of cracking that may occur after installation.

Cracking does not indicate a material fault or even a fault with the fabrication or installation. Often it may be the result of externally induced, mechanical stress, on the benchtops. The two most common sources of stress are from heat (thermal shock) causing expansion or contraction, or high point loads. These could be the result of something that the consumer has done unknowingly or accidentally.

It is best to avoid these risks by using joins and avoiding "L" shape cut-outs.

## Under Bench Appliances

Under bench appliances such as ovens, dishwashers and microwaves can generate heat in a very confined area. To protect the benchtops from the heat, we recommend installing a solid top above the appliances made from the same material as the cabinet carcasses, providing both support and insulation for the benchtops.

Before undertaking any work, refer to your appliance manufacturer guidelines to ensure any work will meet the recommended ventilation requirements for safe use.

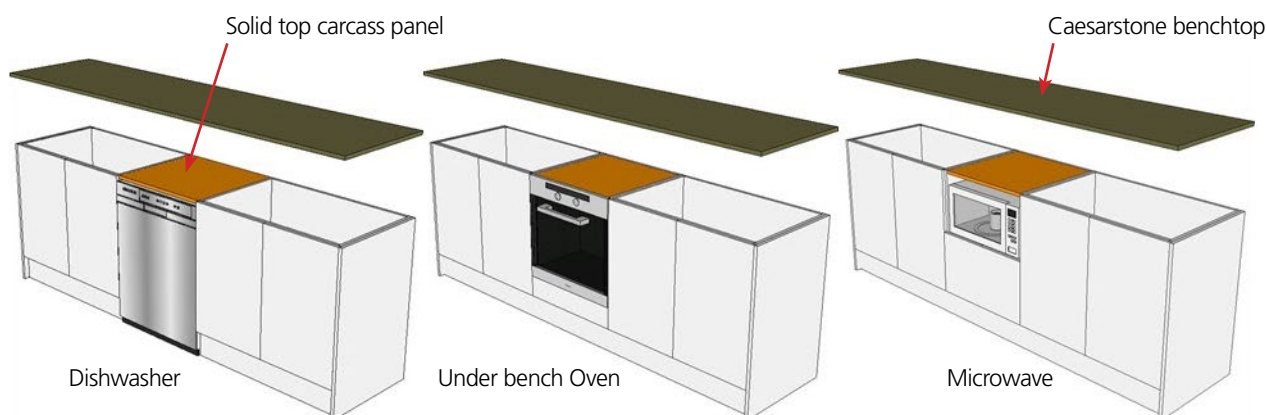

Solid tops are not a replacement for vertical rails. Although a flat panel adds strength, it does not negate the need for solid vertical rails in cabinets where there will be cut-outs.

Ideally, cabinets should have vinyl wrapped solid timber vertical rails to provide maximum strength.

Drawer cabinets should have a solid top where vertical rails are not practical.

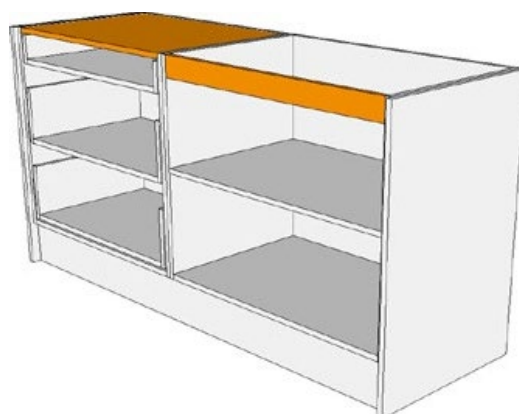

Vertical rails over under bench ovens provide additional support, especially important when the cooktop cut-out is above the oven.



## Cooktop Locations

Avoid having cooktops located above drawer units as this may restrict the use of vertical rails and potentially weaken the support structure under the benchtop.

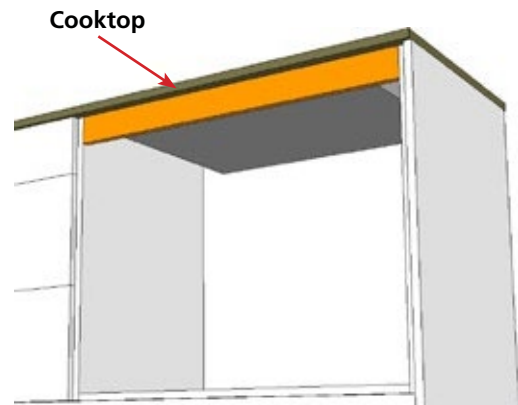
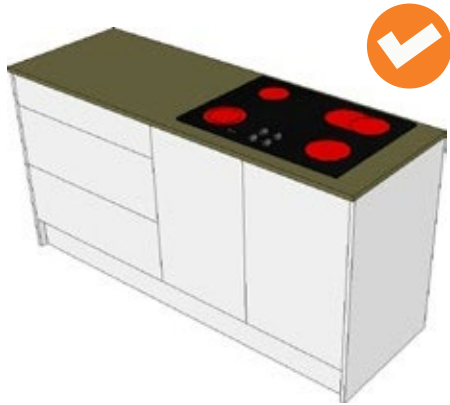
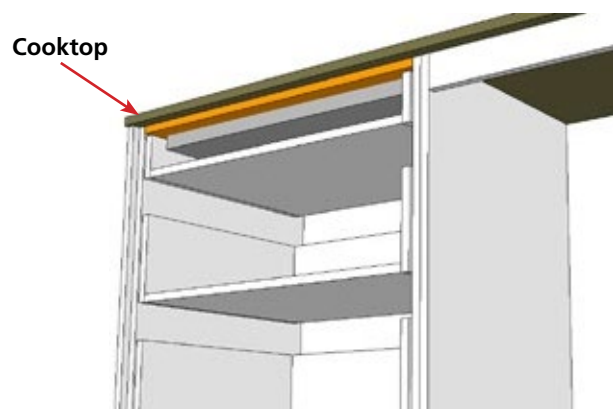

Horizontal rails under a sink or cooktop tend to have a large portion cut-out leaving the support inadequate for the benchtops. Keep in mind the benchtop will also have a cut-out for the appliance without support underneath. (pictured right)

We recommend the use of vertical vinyl wrapped solid timber rails or similar robust vertical supports to add strength.



## Induction Cooktops

Many induction cooktop manufacturers recommend ventilation near or around the perimeter of the cooktop to provide airflow to fans within the cooktop unit. Installing vents into the surrounding cupboards is an option. If incorporating vents into the rail under a cooktop, ensure there is no compromise to the weight support strength of the rail. The installation of all cooktops must always adhere to manufacturer instructions and Caesarstone's front support rail recommendations.

# Overhangs

An overhang is a surface not directly supported by a construction underneath. For example, a surface that extends past the edge of the supporting cabinet for use as a benchtop.

Laminating another piece of the same colour Caesarstone slab to the underneath of the benchtop surface can provide extra overhang strength. Attaching the slab pieces back to back ensures the polished surface remains visible underneath.

Alternative methods to laminating are shown below such as using a mitred top and return. In some cases, the inclusion of a suitable substrate material is preferable to increase the strength, support and visual depth of the benchtop overhang.

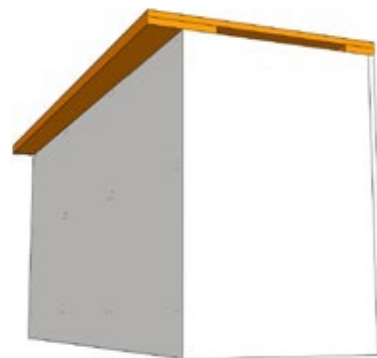

**End Elevation view - Mitred Top / Mitred Returns 40mm**

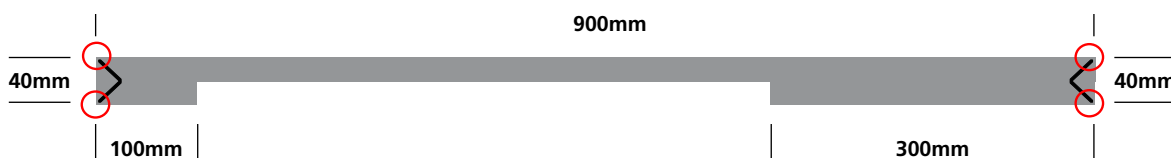

**End Elevation view - Mitred Top with substrate**

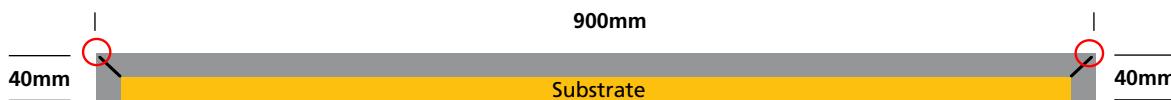

**End Elevation view - Mitred Top / Mitred Returns >40mm**

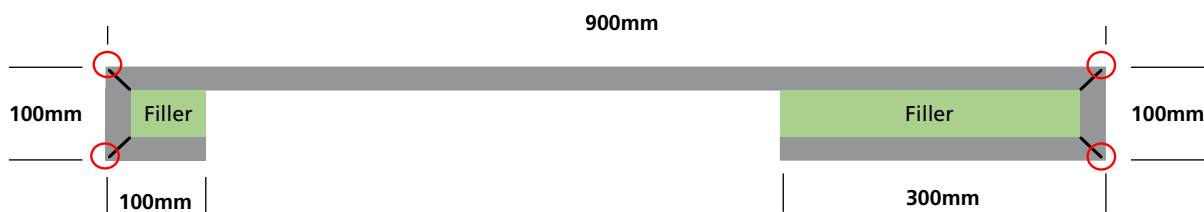

The permitted overhang dimensions must be determined by a professional and is dependent on several factors, such as:

- The complete length to width ratio of the surface relative to the length and width ratio of the overhang.
- Whether the overhang is supported on one or more sides by a wall or other supporting fixture.

The next table provides approximate guidelines for the support requirements for overhangs. Supports are dependent on the application; if the overhangs are subject to high loads, supports are necessary regardless of the recommendations below.

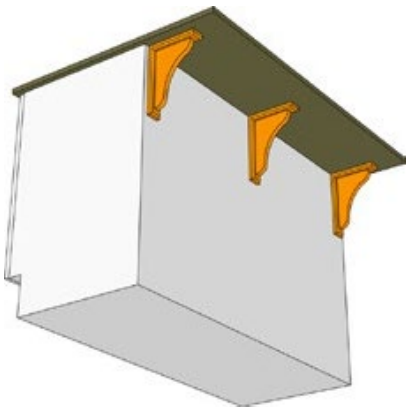

Types of Overhang	20mm Thickness Slabs (or 40mm laminations)	Comments
Unsupported Overhangs	Less than 300mm overhang	No additional support required
Supported Overhangs	300mm to 500 mm	Support brackets at 600mm intervals
	Greater than 500 mm	Legs, columns or panels required

## Carcass Rail Support

Any carcass structure which a Caesarstone benchtop or surface is applied to must be able to support the weight of the benchtop fully, and any additional load applied during normal daily use.

For this reason, Caesarstone always recommends the use of vertical rails – ideally vinyl wrapped solid timber that will provide full perimeter support front and back of all carcasses. Any rail support must not flex or sag regardless of the span.

The use of vinyl wrapped, solid timber vertical rail provides greater strength and better support.

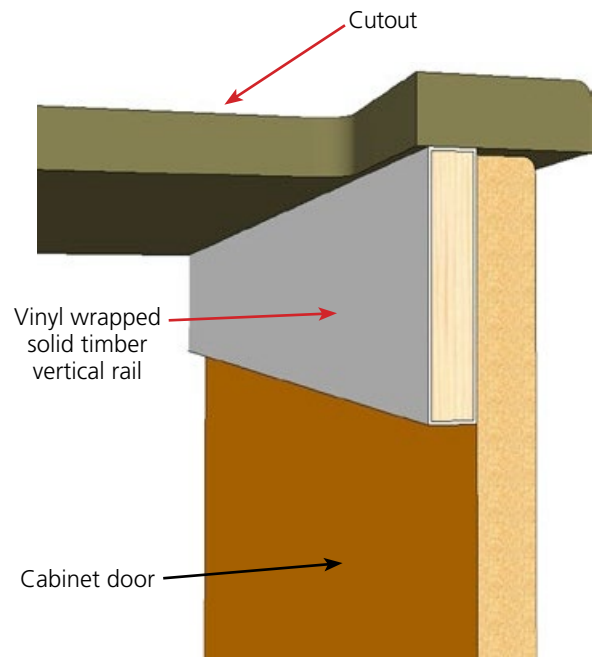

For carcasses with large spans, construct the rear and especially the front rail using sturdy, rigid materials that will not flex under load. In these circumstances, a double laminated, vinyl wrapped, solid timber rail or one made from aluminium or steel may be necessary.

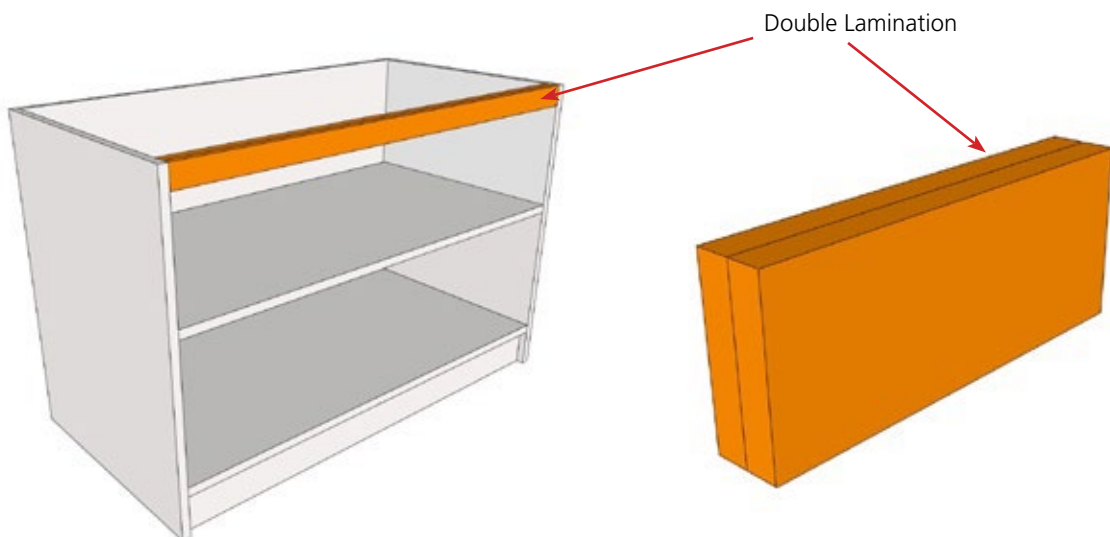

## Cantilever Islands

Caesarstone slabs must be installed flat on a rigid frame or base that cannot bend or flex. Cantilever islands should be constructed from a steel frame and must be capable of supporting the full weight of Caesarstone slabs, negating any movement or sagging.

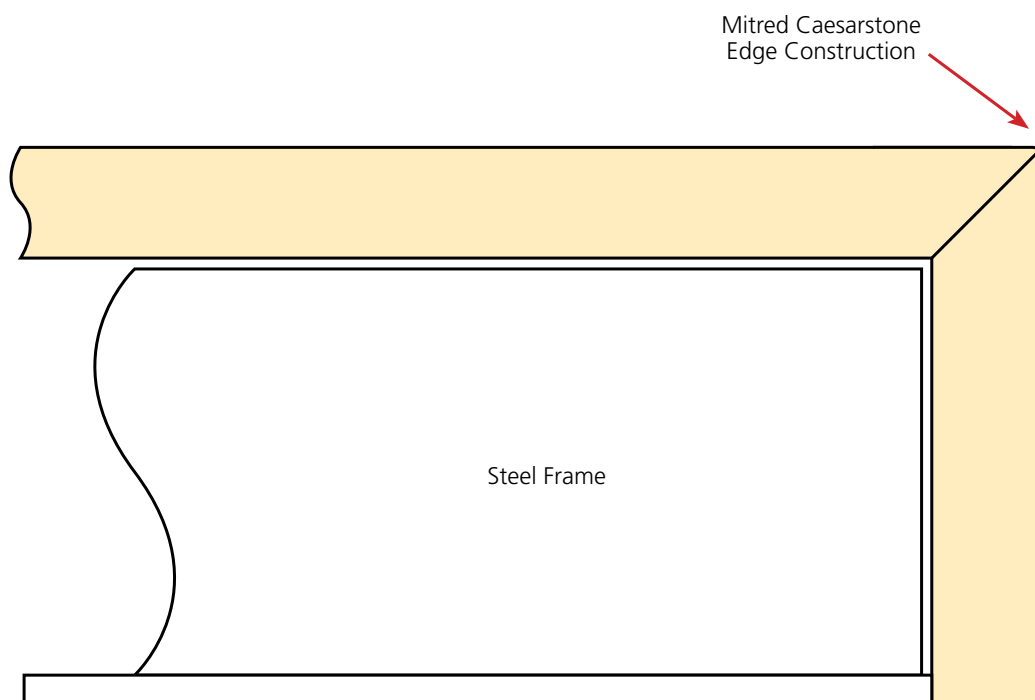
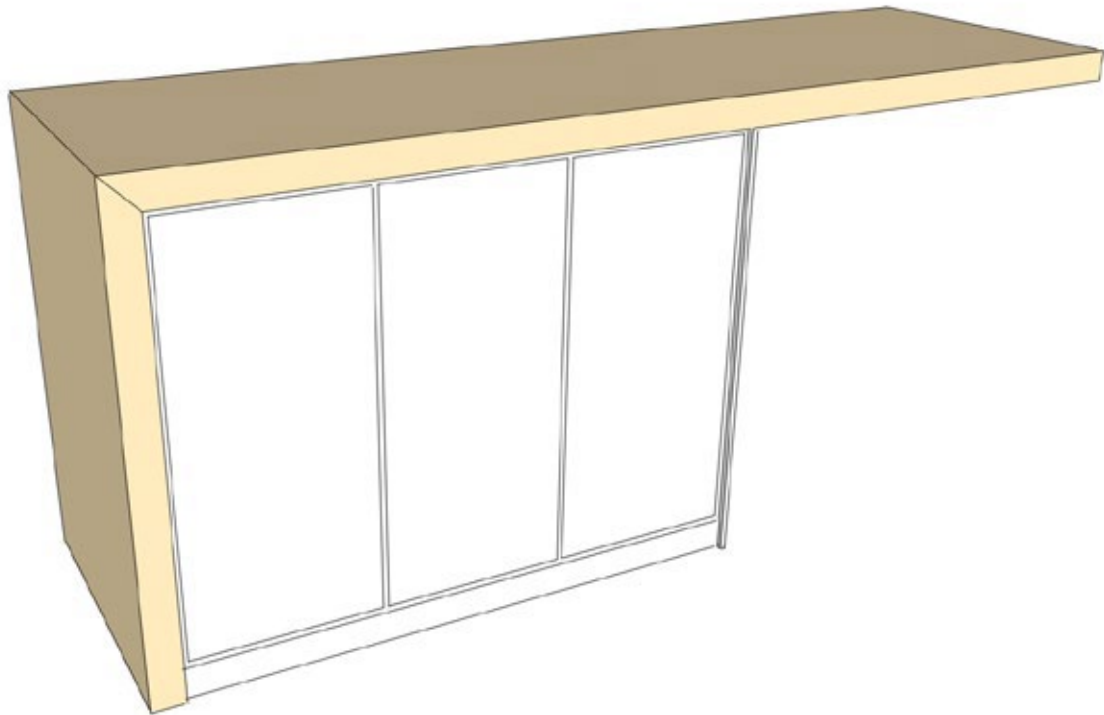

## Benchtop Cut-Outs

When incorporating sinks, cooktops, or other appliances into the benchtops, consider the following:

- Cut-outs are for purposes of installing sinks, cooktops and other accessories.
- Preparation of cut-outs must adhere to the instructions and recommendations specified by the appliance manufacturer.
- Include a minimum radius of 15mm for all internal corners in cut-outs (Figure 1). The larger the radius, the stronger the corner.

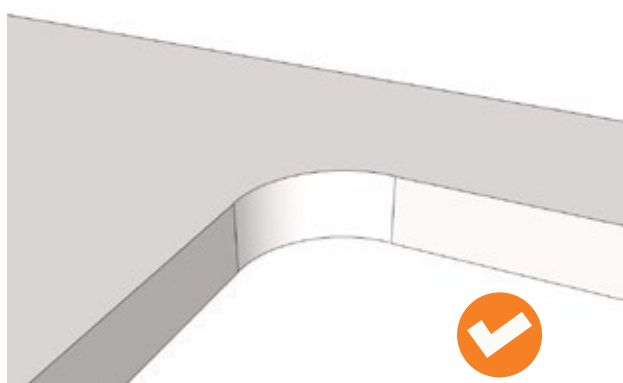

Figure 1

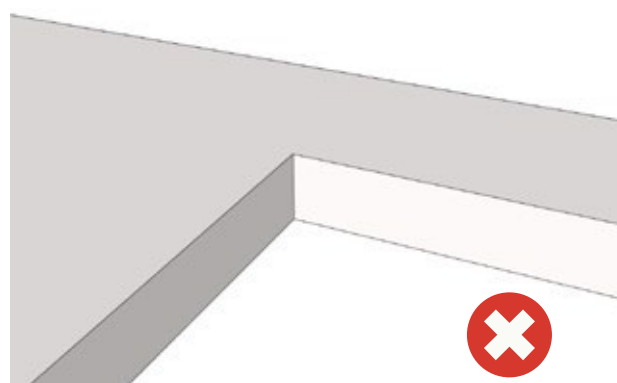

Figure 2

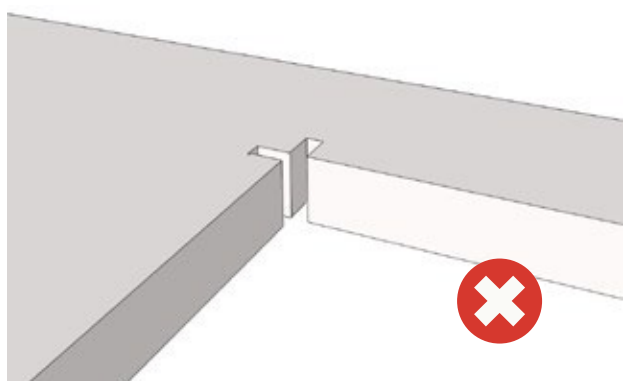

Figure 3

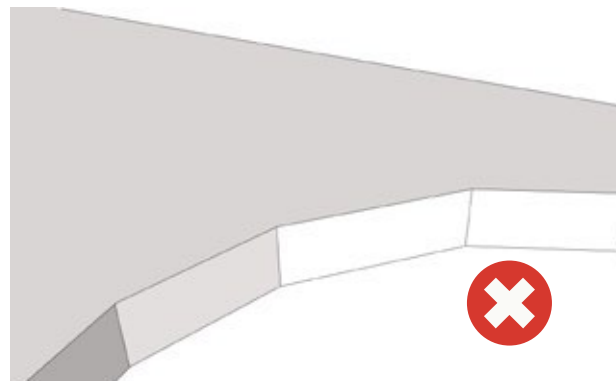
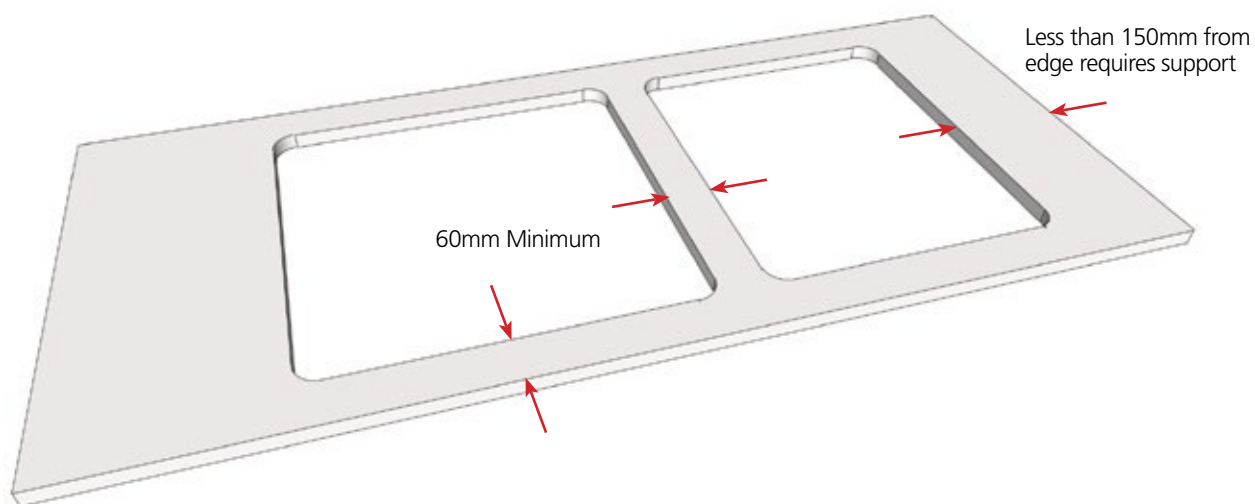

Figure 4

- Do not square cut (Figure 2) or cross-cut (Figure 3) corners.
- Do not cut large radius in sections (Figure 4); these need to be one continuous smooth radius.
- Avoid reducing the thickness of the surface when preparing the cut-out. Reductions in surface thickness for flush-mounted sinks and cooktops or draining grooves must not compromise the strength and support of the surface.
- The distance between a cut-out and an edge, or join, must be no less than 60mm. The greater the distance, the stronger the area.
- If the distance between a cut-out and an edge or join is less than 150mm, the area must be supported. The space between the cut-out and the edge, or join, must be over the junction between the base cabinets. Alternatively, fit a solid support strip underneath the area.

## Cut-Out Surrounds

Consider the minimum recommended dimensions when designing cut-outs for appliances and sinks.



## Large Cut-Outs

If a cut-out leaves front and back benchtop rail widths of less than 60mm, it is advisable to consider making the rails from separate pieces to avoid problems with cracking.

Separate rails abutted to the end of the benchtop are recommended for cut-outs less than 60mm from an edge.

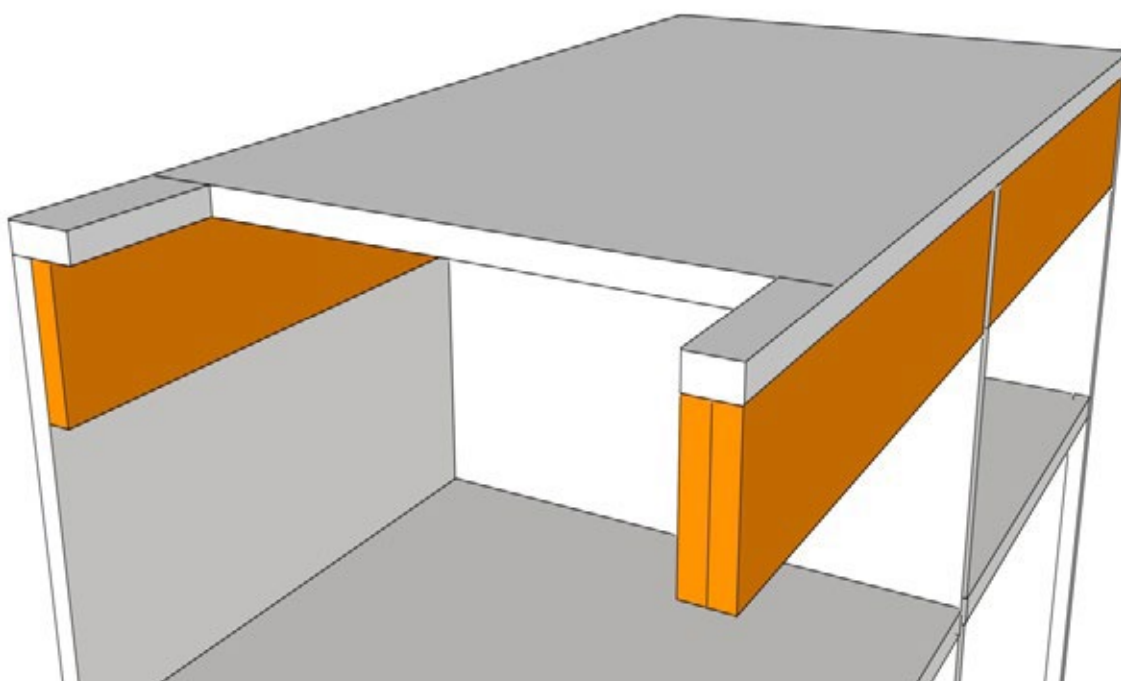

## Cut-Out Supports

Cut-outs within Caesarstone benchtops for sinks or cooktops should always be supported to ensure the Caesarstone surface is not bearing the direct weight of any heavy loading placed on the benchtop surface.

**For this reason, Caesarstone always recommends the use of vertical rails that will fully support the weight of the benchtop and any additional heavy loads placed on the benchtop. Any rail support must not flex or sag regardless of the span to avoid stress on the Caesarstone material.**

The use of vinyl wrapped, solid timber vertical rails have the advantage of greater strength and better support.

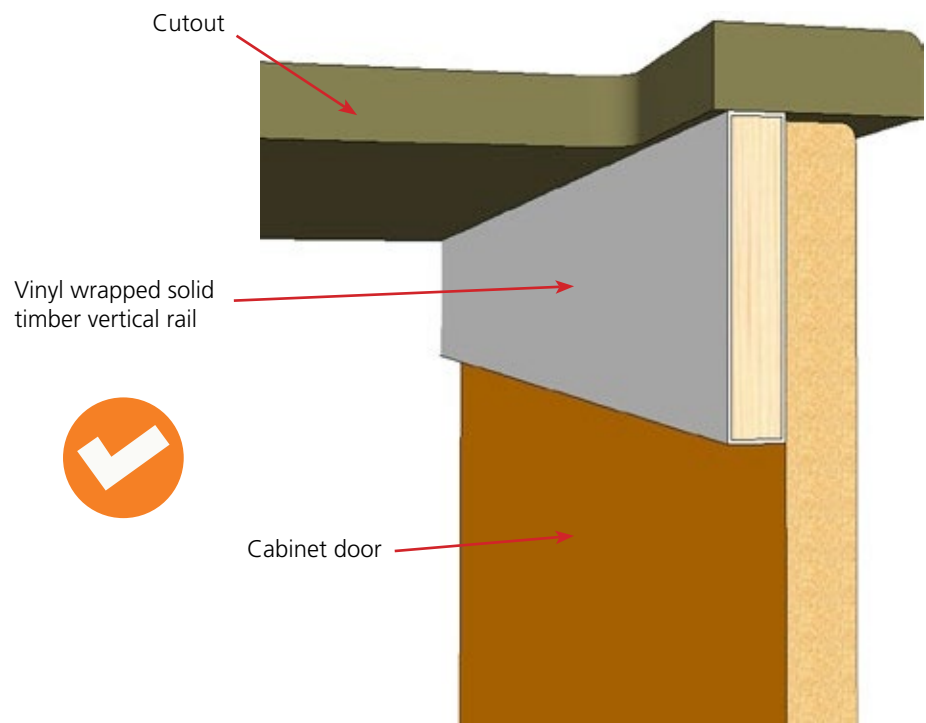

The use of an MDF vertical rail is still better than having a flat rail.

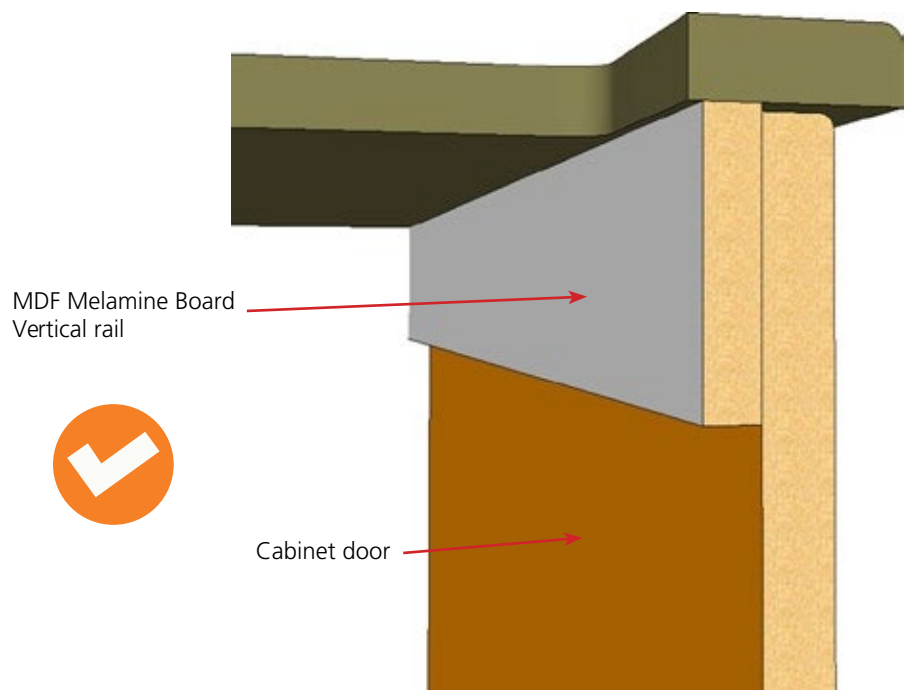

Horizontal rails are not advisable for use below an appliance or sink installation. Most appliance installations require a large cut-out from the front rail reducing its ability to support the benchtops properly.

The installation of cut-out supports is dependent upon the quality of the structure used for the benchtops.

**If the structure is not of adequate quality, address this with the other parties involved before commencing any installation.**

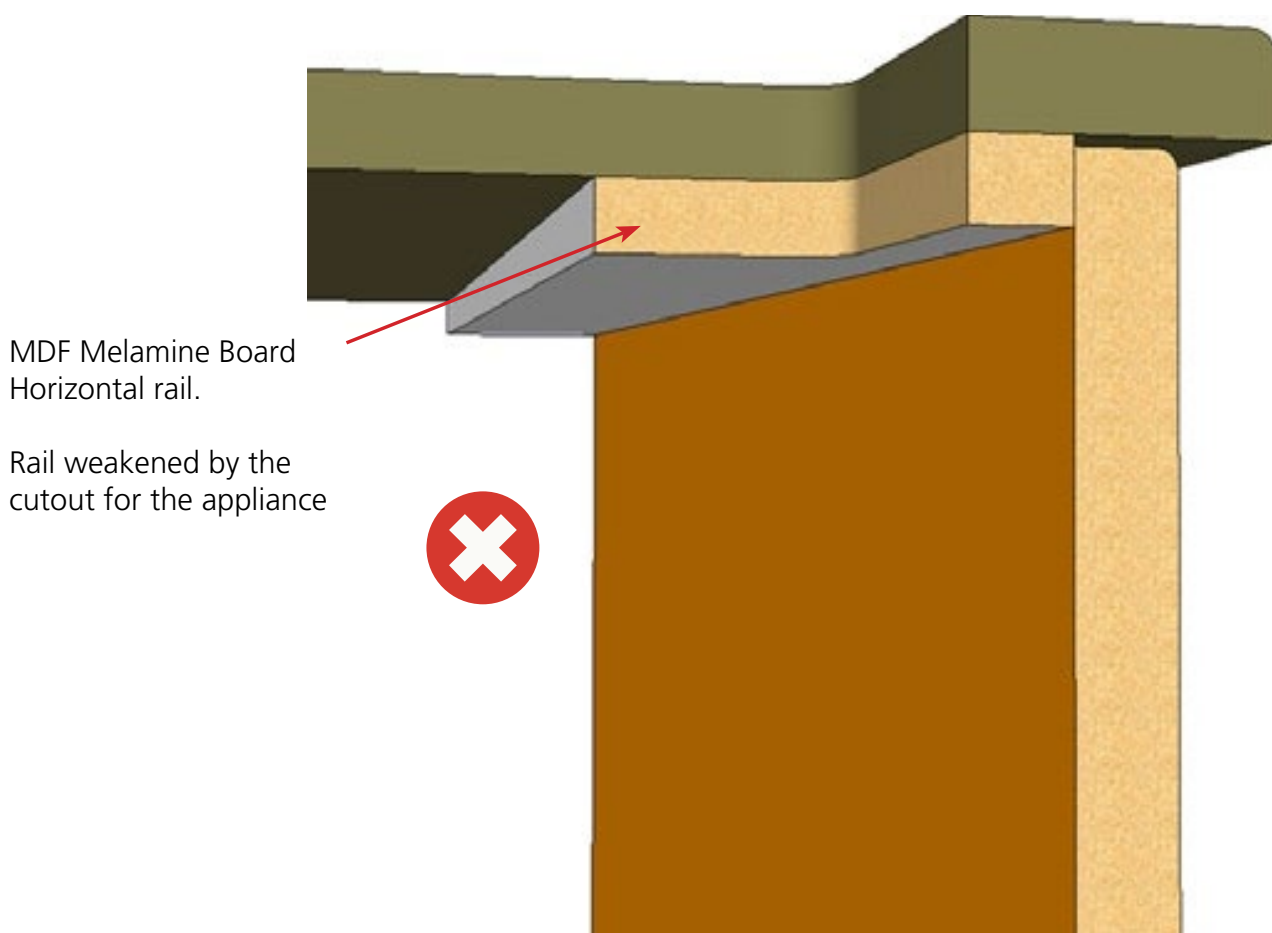



## Sink Drainers

Sink draining grooves are often cut into the surface of the material when incorporating under-mount sinks. In this instance, the following fabrication considerations apply:



1. Drainage grooves or wash plane surface are polished to the same level of finish as the factory polish finish of a Caesarstone slab. The quality and performance of any machined sink drainer is the responsibility of the Stonemason.
2. The depth of grooves are not so deep they affect the strength of the benchtop around that area. Grooves are to be no deeper than 15% of the thickness of the slab. For example, 3mm deep grooves for a 20mm slab. The area on the underside of the draining grooves may require additional support.
3. Drainage grooves may require cleaning with a soft bristle brush.
4. Installation of square corner flush mount sinks must comply with the requirement to maintain a minimum 15mm radius on all internal corners.

Caesarstone's Lifetime Warranty does not cover the fabrication process.

# Sink Cut-Outs

Note - The recommended edge profile for the under-mount sink cut-out should be a minimum 6mm radius edge on the benchtop surface edge to minimise the risk of chipping or damage. The greater the profile, the more durable the edge will be.

Cut-outs for top mount sinks must always be core drilled in each corner to eliminate stress points and smoothly integrate to all straight cuts. Cut-out and corner details must never be roughly cut with an angle grinder.

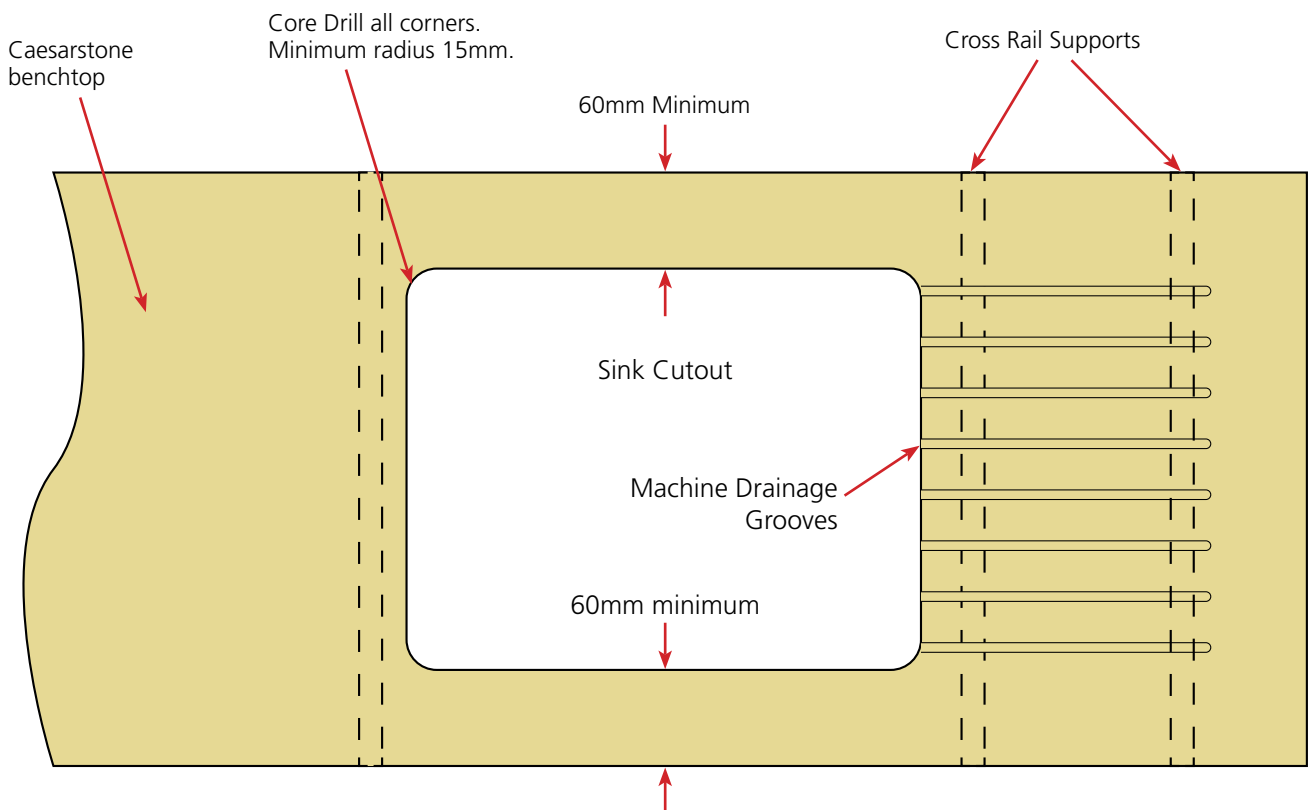

# Kitchen Splashbacks

Caesarstone splashbacks are low maintenance, easy to clean, grout-free surfaces offering a seamless look and continuity of benchtop colour. Ideal for use behind sinks. Caesarstone splashbacks provide reduced lead times with same day installation as the benchtop.

## Where can Caesarstone be used?

Electric cooktops (freestanding or bench mounted) and Induction cooktops

- For both Electric and Induction cooktops it is a requirement to have a minimum 50mm gap from the back edge of the cooktop to the Caesarstone splashback.

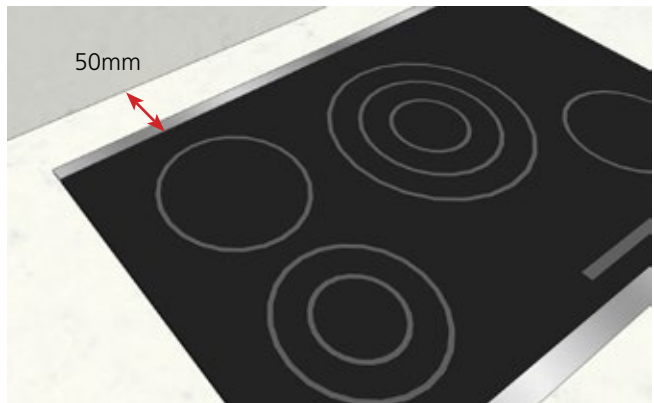

50mm minimum clearance from splashback for electric cooktops

Gas cooktops (freestanding or bench mounted)

- For gas cooktops, it is a requirement for a minimum 200mm gap from the periphery of the gas burner to the Caesarstone splashback as per the AS/NZS 5601 Gas Installations Guidelines.

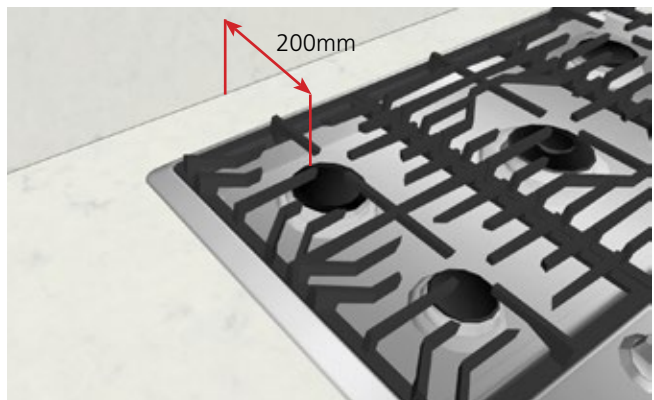

200mm minimum clearance from the splashback to the gas burner element

When designing or installing splashbacks, compliance to all Australian standards and guidelines needs to be considered by all parties involved in the design, manufacture and installation of a kitchen.

## Installation Guidelines

- Timber-framed wall construction should use fibre cement sheeting installed as per relevant guidelines behind Caesarstone splashback applications. Brick wall construction should use cement-based render behind Caesarstone splashback applications.
- For splashbacks, "L" shape cut-outs should incorporate a suitable gap filled with an appropriate flexible sealant to allow for the thermal expansion and subsequent contraction of the surface.
- Cut-outs for items such as power points should be core drilled to produce radius internal corners, i.e. two 50mm core drilled holes. Avoid cross-cutting at all times.
- We recommend the use of a neutral cure flexible silicone for bonding the splashback to the wall cladding and neutral cure coloured silicone for sealing the joints.
- Items such as utensil racks can fix to a Caesarstone splashback. Making fixing holes requires either a diamond-tipped drill, tungsten or sapphire-tipped drill bit on a slow variable speed with no hammer action. Start with a small hole and gradually increase the diameter to the required size. Use plastic wall plugs and stainless-steel screws. The wall plug must not penetrate the wall behind the Caesarstone surface. If the holes are close to a corner, leave at least 5cm distance between the hole and the edges.

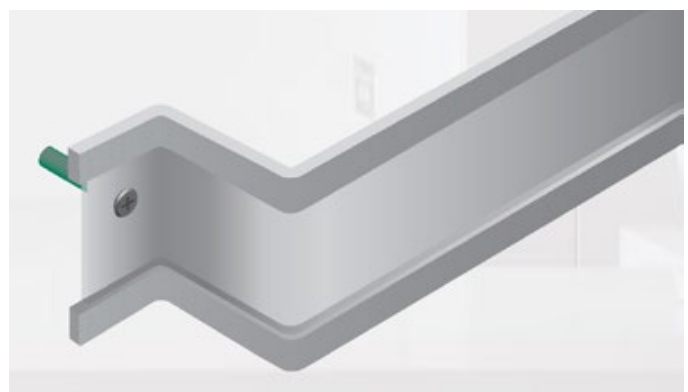
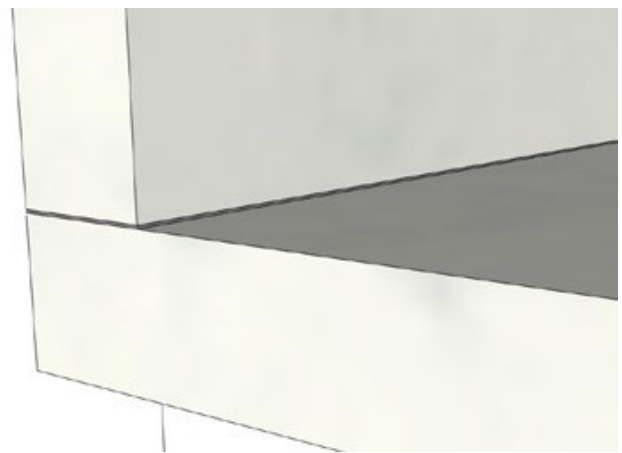
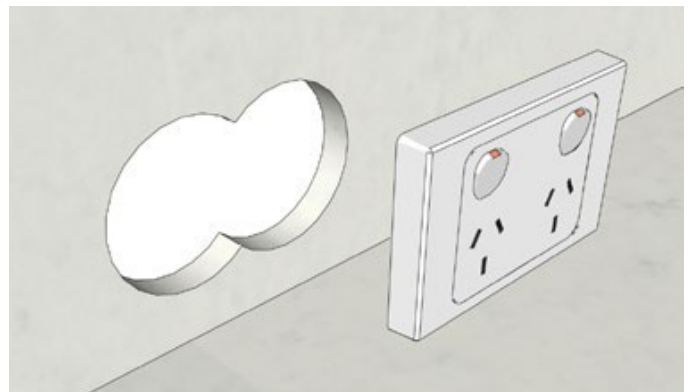
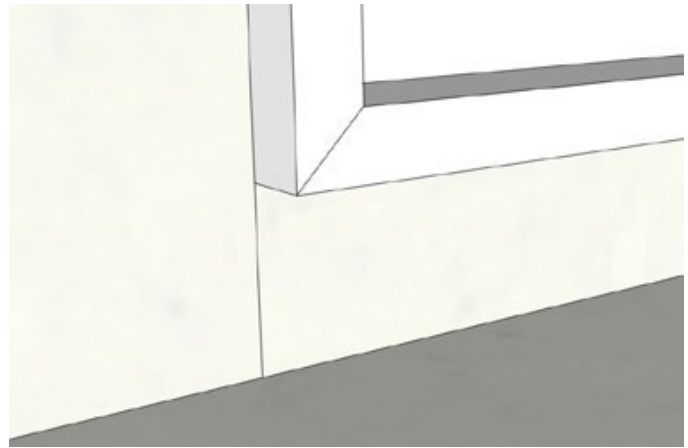

## Edge Profiles

Caesarstone can accommodate many edge profile designs. The most popular choices for Caesarstone Australia customers are the Aris Edge for 20mm and the Mitred Edge for 40mm surfaces. The lamination method can also achieve a 40mm appearance.

It is essential to consider the following factors when specifying edge profiles:

- All exposed edges should be fabricated and finished to the same finish as the surface.
- The top and bottom of edges must be rounded and not square edges. The larger the surface area of the edge (i.e. radius), the more resistant the edge is to chipping.
- **All edge profiles should have a minimum radius of 3mm - 4mm. For added durability, the best option is a 6mm radius.**
- Undermount sinks should have a minimum radius of 6mm on the upper edge of the Caesarstone.

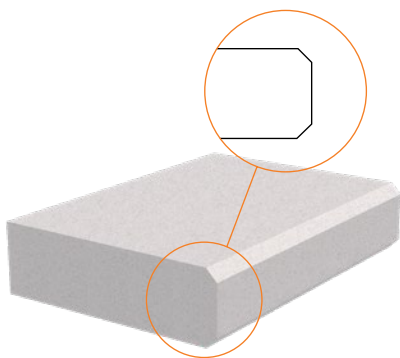

**Aris**

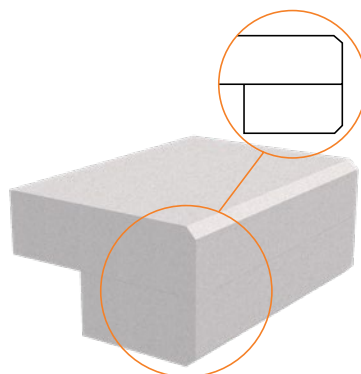

**Aris Laminated**  
3mm - 4mm  
Recommended

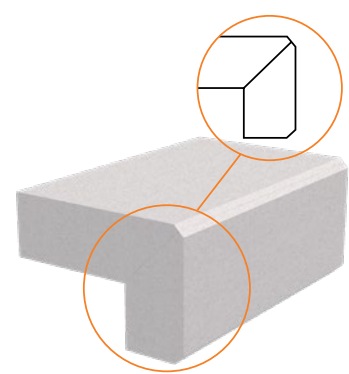

**Aris Mitred**

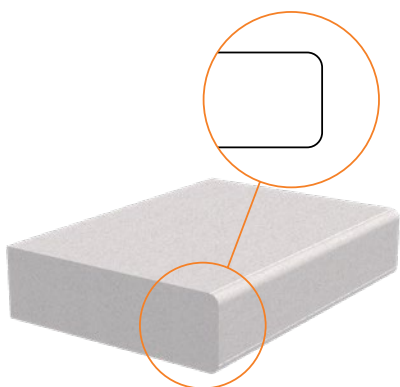

**Pencil Round**  
3mm - 4mm  
Recommended

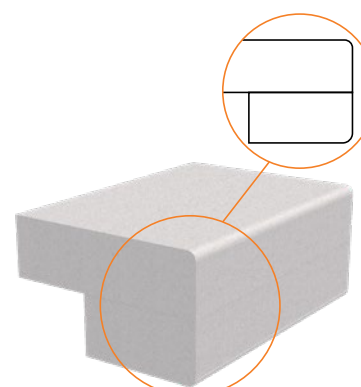

**Pencil Round Laminated**  
3mm - 4mm  
Recommended

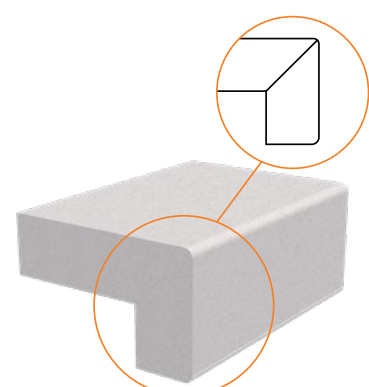

**Pencil Round Mitred**  
3mm - 4mm  
Recommended

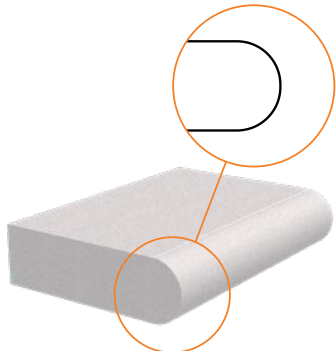

**Bullnose**

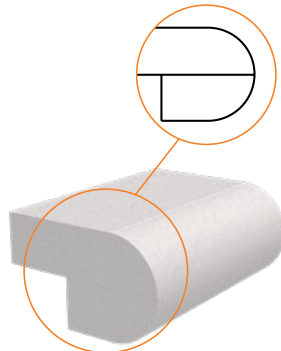

**Bullnose Laminated**  
3mm - 4mm  
Recommended

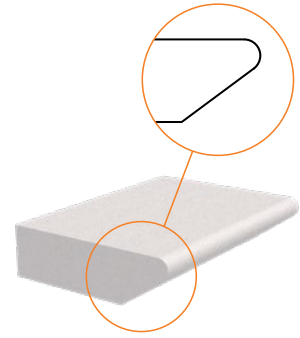

**Shark Nose**

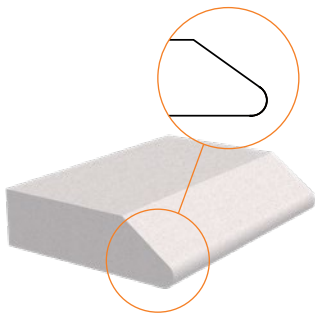

**Splayed**  
Recommended for  
furniture

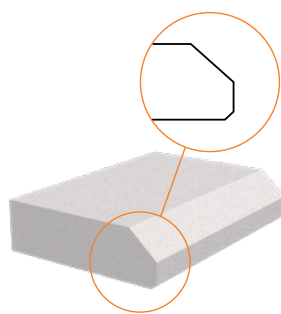

**Bevelled**  
3mm - 4mm  
Recommended

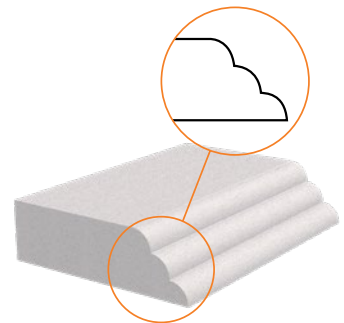

**Waterfall**

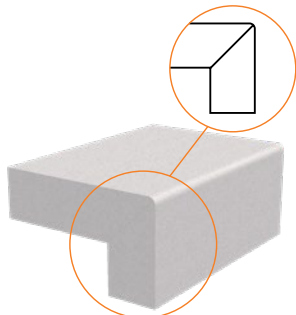

**Mitred Apron**  
Recommended for  
Supernatural Designs

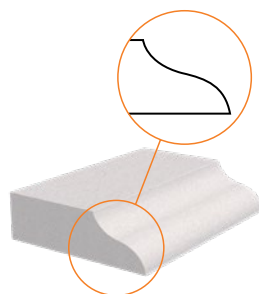

**Lambs Tongue**

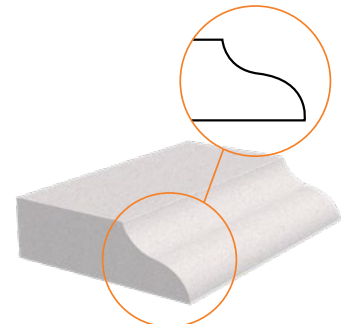

**Classic 20mm  
Lambs Tongue**

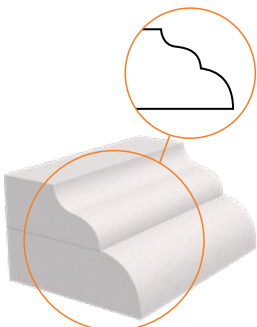

**Provincial 40mm  
Lambs Tongue**

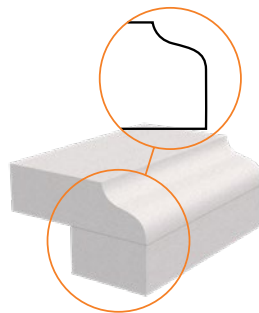

**Traditional 40mm  
Lambs Tongue**



**Square Edge**  
Never finish edges  
square like this, as  
impact to the edge may  
result in chipping.

## Preparing the Base Units & Cabinets

- Caesarstone surfaces are installed on top of cabinets and not fixed to the wall. Before installing the surface, ensure cabinets are complete, stable, level and suitable for bearing the weight of the surface plus any other heavy applied loading including full sinks.
- **Caesarstone surfaces require a sturdy, weight supporting perimeter frame or a full deck (solid carcass) support.**
- Verify the benchtop is adequately supported in areas of joins, cut-outs and over spaces for appliances such as dishwashers, ovens, washing machines and the like.
- Provide side-to-side support beams under the surface for cut-outs longer than 600mm.
- Provide support under all benchtop joins.
- Attach a board between the cabinet tops on both sides of under bench appliances that generate heat.
- Extra reinforcement of the cabinets or the surface may be necessary for 20mm surfaces. A full carcass panel in the top of the cabinets can address this.

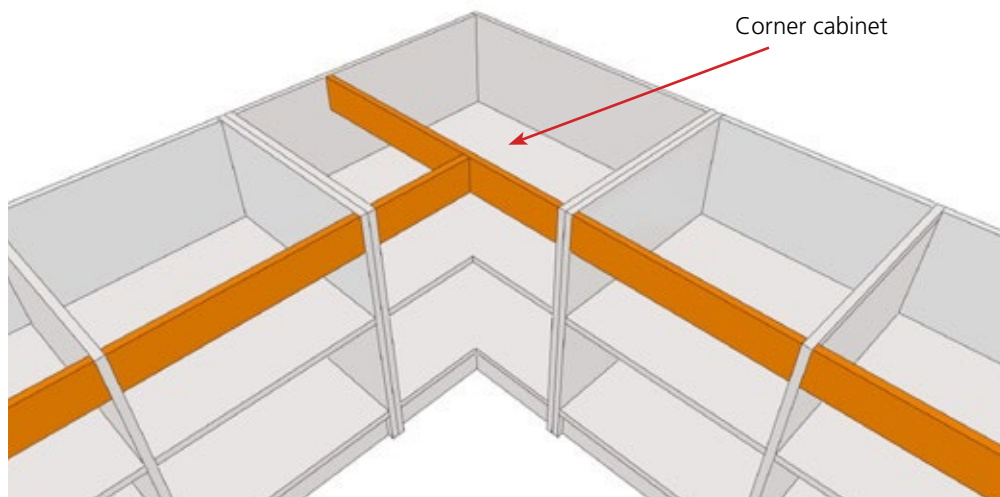
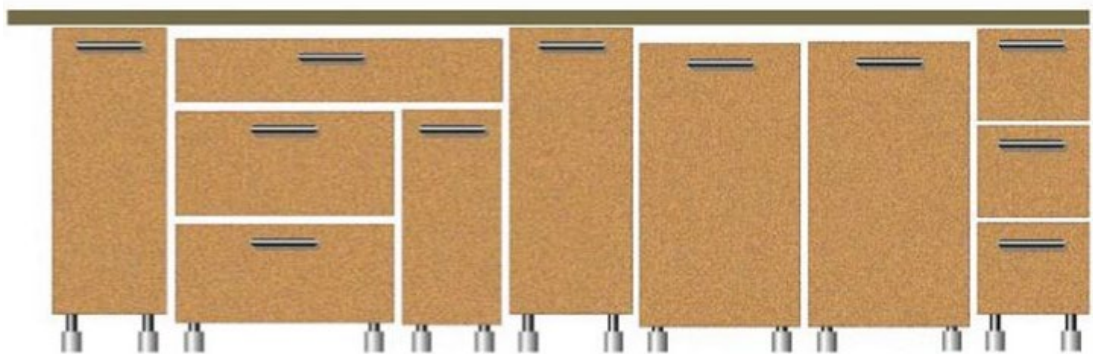
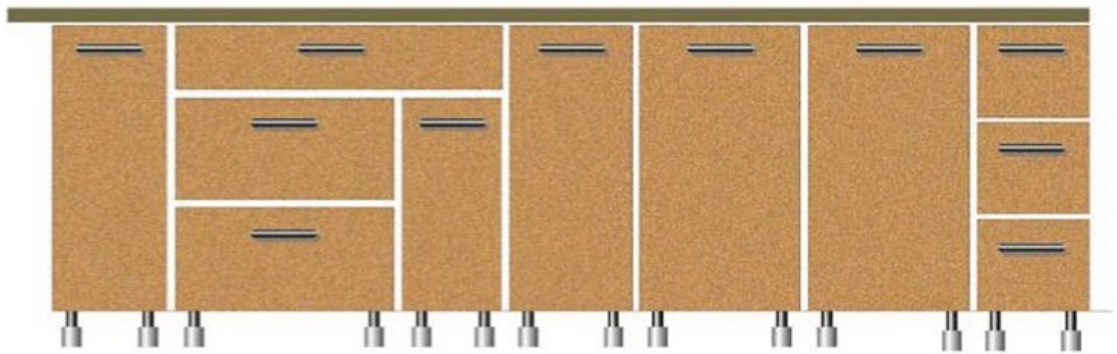

## Cabinet Support

Plinths provide a robust and stable base for the cabinets and are considered best practice. They must be levelled properly and secured to the floor and wall.

Cabinets should be placed and fixed securely to ensure that there is no movement under load and there is a level surface for the benchtop.

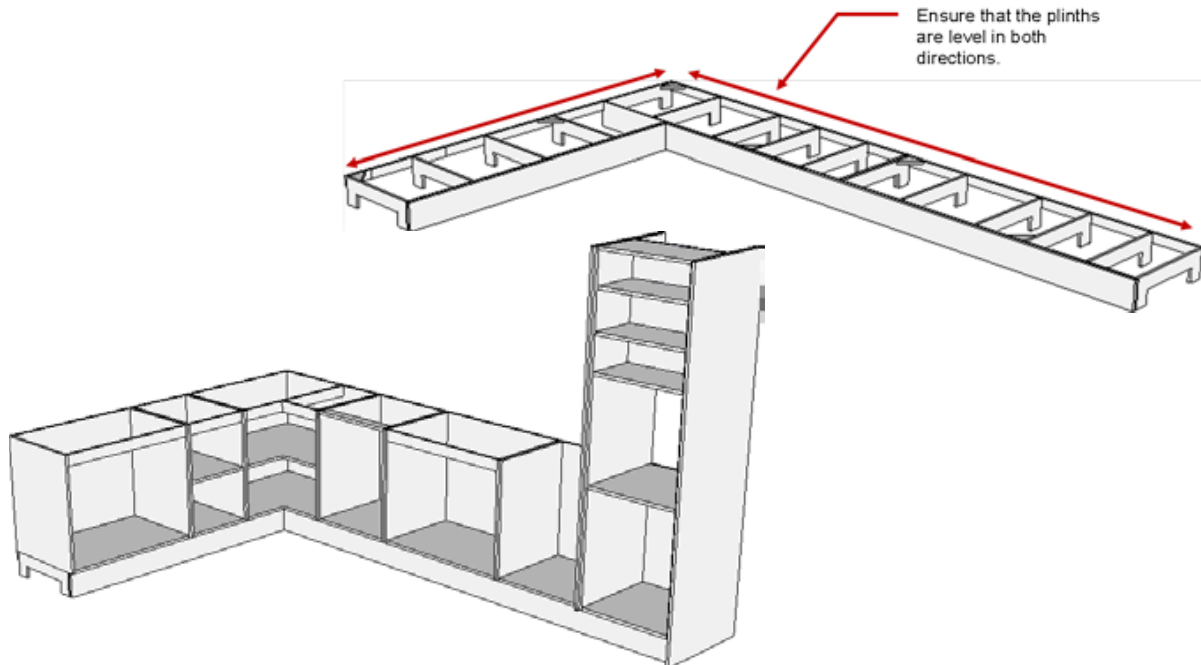

## Finishing Touches

Once the installation is complete, ensure the slab surface is clean and the work area tidy. If undertaking further construction at the job site after finishing the installation of the benchtop or Caesarstone surface, ensure proper protection of the surface by covering the entire top with corrugated cardboard or another protective material.

Make the customer aware that any following tradesmen must NOT use the new benchtop as a workbench, step or standing platform, and any tradesmen using strong solvents or adhesive must show due care. Remind the customer to register for their 10 Year Limited Warranty at [www.caesarstone.com.au](http://www.caesarstone.com.au).

Caesarstone strongly recommends the customer confirm in writing their satisfaction with the material and quality of finish at the end of the job to protect the Stonemason and kitchen company against damage caused by others. Take photos after completing the installation of benchtops. The images here are an excellent example of what can happen after the installation of benchtops.

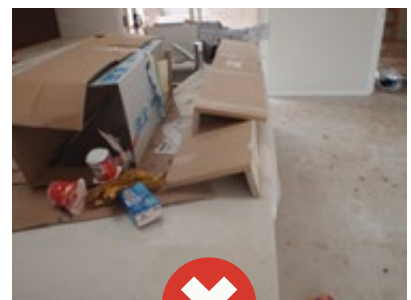
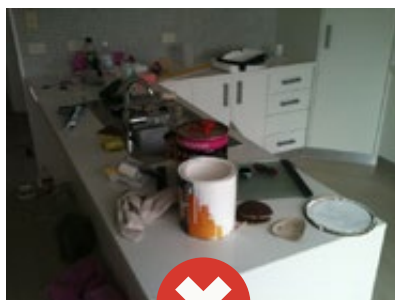



## Tabletops

When installing a Caesarstone surface as a freestanding tabletop, the base must fully support the weight of the Caesarstone tabletop. All edges should be radiused to at least 6mm to reduce the risk of damage from chairs and the like.

Caesarstone should be bonded to the substrate with epoxy and then screw fixed to the substrate.



## Tabletop Frames

Caesarstone is an ideal surface for furniture and large benches. When using Caesarstone in these applications, the perimeter and internal supports must not sag or move due to the weight of the Caesarstone or any other additional surface loading.

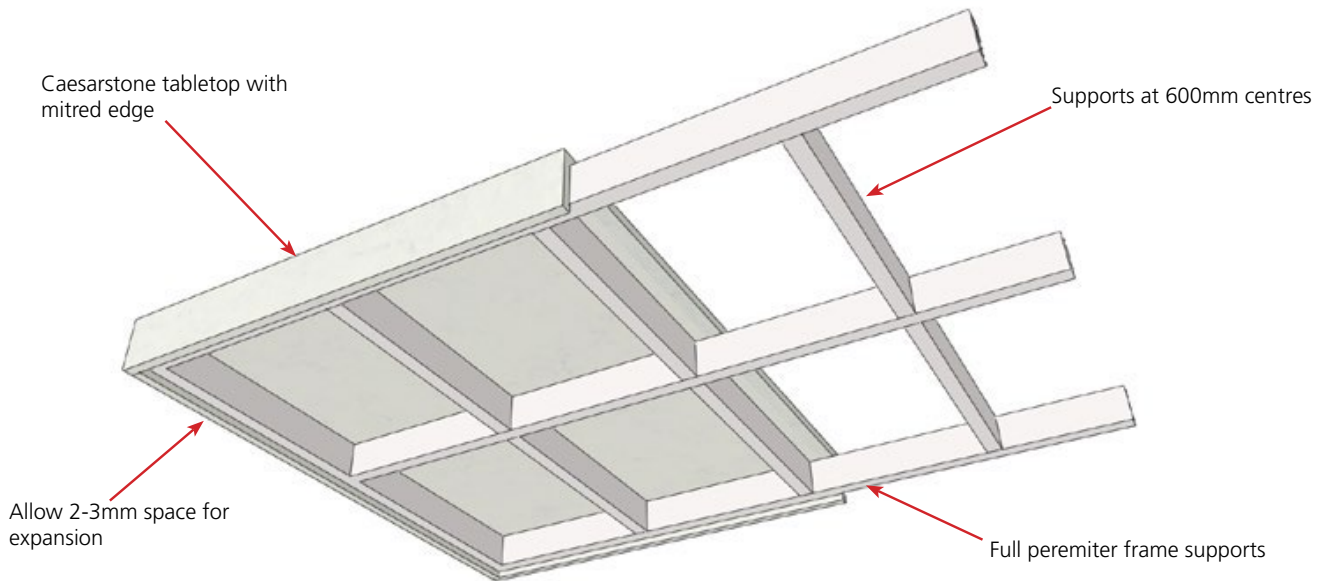

# Vanities

Caesarstone can be used to create a vanity unit in several ways.

- Where the material itself forms the receptacle that will hold water or where water is running directly onto the surface of the Caesarstone. Not suitable for boiling water due to the risk of thermal shock to the surface.

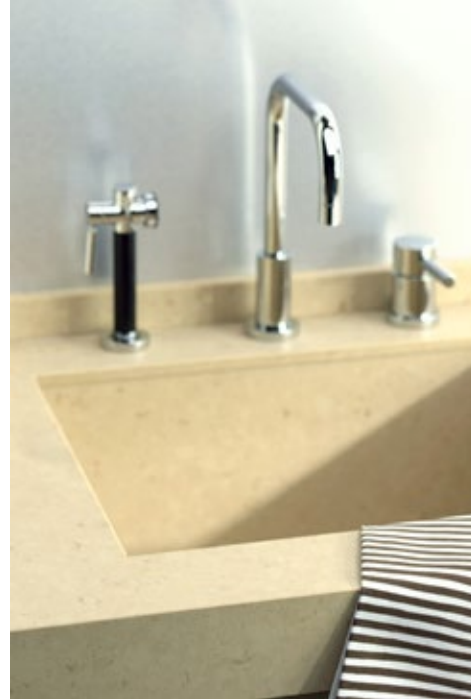

- For a traditional basin design where the top and basin are Caesarstone.
- Where Caesarstone works in conjunction with a washbasin or vessel to form a vanity top; this can be using an under bench basin or an over bench vessel.



**Under Mount Sink**

Photo: Winnie & Fred Designs



**Top Mount Sink**

Photo: Kitchens Victoria

## Laundry / Kitchen

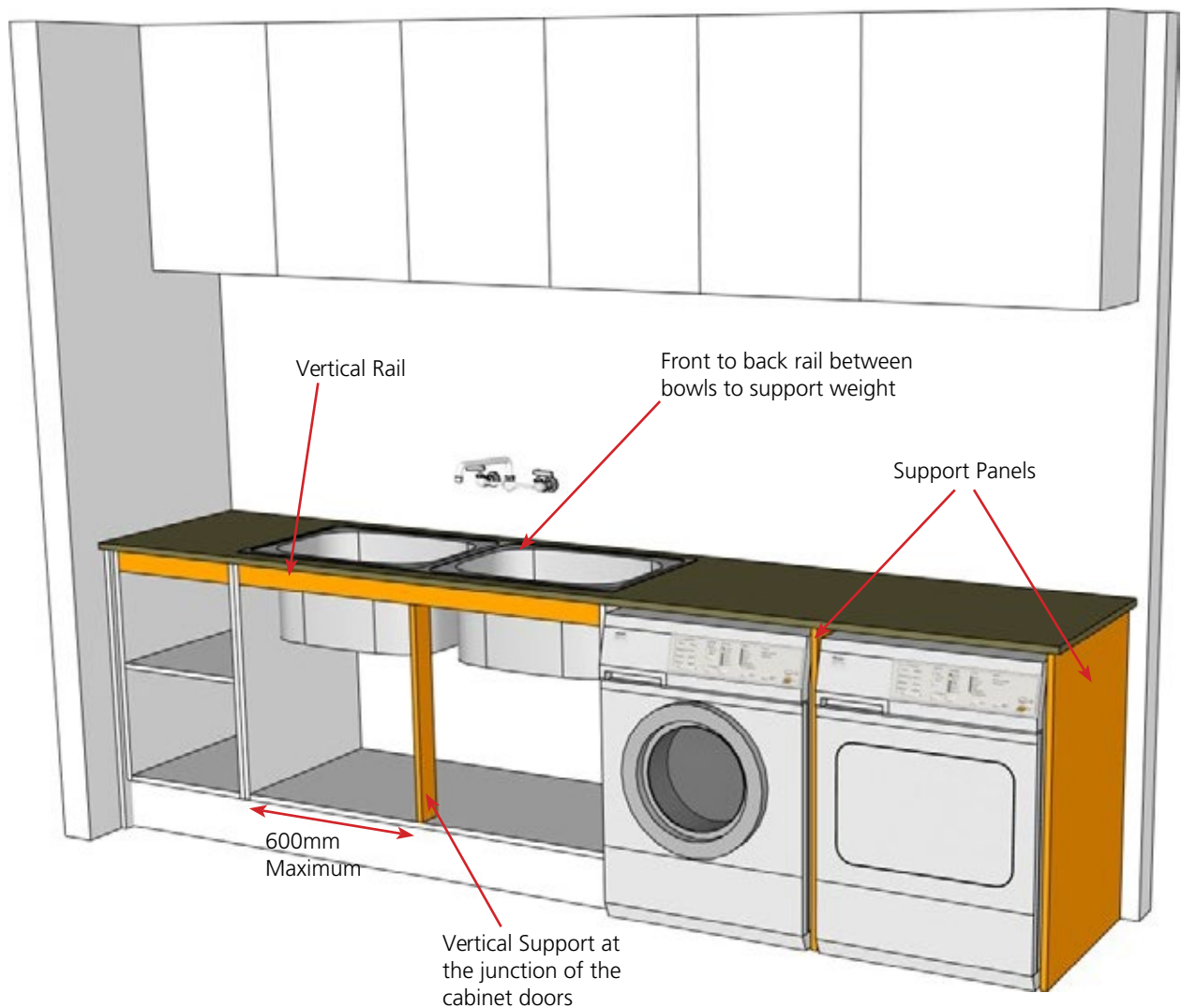

## Laundry Tubs

Installing large sinks into laundries and kitchens requires additional consideration. Above is an example of a dual 45L sink needing a wide cabinet for installation.

The total capacity of the double sink is 90L with each litre of water weighing 1kg. The weight potential is approximately 90kg if both sinks are full of water; equivalent to a person standing on the top in an area with a large cut-out.

If there are two sinks, we recommend adding a rail between the bowls. Unless the cabinets are reinforced to adequately support the additional weight, there is a high risk of a benchtop failure.

## Washing Machine & Dryer

Where washing machines and dryers are installed below the benchtop, providing additional support is essential.

It is advisable to install a vertical support panel between the appliances with either a support panel or a cabinet placed either side to ensure benchtops have adequate support.

The heat generated by such appliances, especially dryers, also needs consideration. Some machines exhaust heat through vents at the front or back, while others may be ducted.

A panel may need to be installed below benchtops to protect them from the heat.



## Heat Resistance

Caesarstone surfaces can tolerate moderately hot temperatures for brief periods. Prolonged exposure may result in discolouring or other types of damage.

- Do not expose Caesarstone to excessive heat. If the cookware is too hot to hold, it is too hot to place directly onto a Caesarstone surface.
- If exposing the surface to temperatures higher than 70°C, the surface will require support from underneath to prevent warping.

**Always use an insulator trivet, chopping board or heat pad. Never place hot cookware directly onto the surface of any Caesarstone slab.**



The example shows heat concentration on one area of the benchtop due to a pot with a high thermal load. The use of a heat-pad eliminates the problem with no heat transfer to the benchtops.



Heat can cause a benchtop to expand rapidly in a very localised area. In contrast, the adjacent surface area and any adhesive will remain cold and not expand increasing the potential for cracking.

Therefore, placing a pot directly from the cooktop onto the benchtop creates two issues — a sudden change in temperature (thermal shock) and a high thermal load, an increase in the amount of heat present.

Although cracking may not occur immediately, without the application of proper precautions such as heat-pads, cracks may develop over time. The proximity of the affected areas to weaker sections such as cut-outs can increase the likelihood of cracking.

# Care & Maintenance

## Everyday Cleaning

Caesarstone® surfaces require very little maintenance to keep them looking like new. For everyday, routine cleaning of Caesarstone® we recommend wiping the surface with warm soapy water (a mild detergent) and a clean damp cloth, or use our convenient Caesarstone® Spray Cleaner. Do not use the cloth you use to wash the dishes, as it may transfer oils and other contaminants to the Caesarstone® surface.

As Caesarstone® is virtually non-porous, it will never require polishing or sealing. Never attempt to polish the surface and avoid prolonged rubbing in one spot when cleaning.

## Food Preparation

We always recommend cutting on an appropriate cutting board and never directly on the Caesarstone® surface to avoid blunting kitchen knives or damaging the surface of your benchtop.



## Caesarstone® Cleaning Products

Caesarstone® has developed a range of specially formulated cleaning products designed to keep your quartz surfaces looking their best. Caesarstone® Cream Cleanser and Spray Cleaner are available to purchase through our online store.

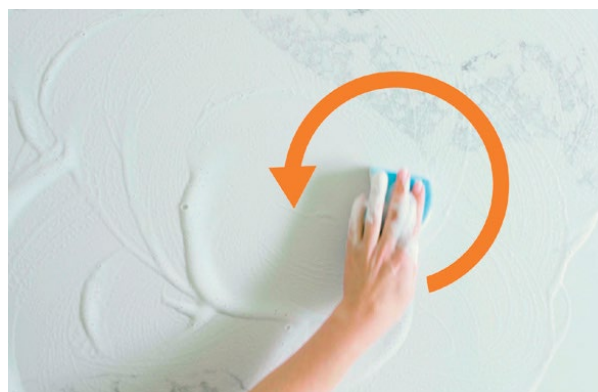

## Cleaning Reference Guide

Substance	Caesarstone® Cream Cleanser	Methylated Spirits	Caesarstone® Spray Cleanser
Red Wine	✓		✓
Beetroot	✓		✓
Coffee / Tea	✓		✓
Cordial	✓		✓
Spices	✓		
Food Oils			✓
Glue / Silicone / Paint		✓	
Tougher, Stubborn Stains	✓		

To remove adhered materials like food, gum and nail polish, first scrape away the excess with a sharp blade. If there are any grey metal marks on the surface, use a small amount of Caesarstone® Cream Cleanser on the light blue sponge side of a 3M™ Scotch-Brite™ Non-Scratch Foam Scrub, gently rub over the mark and thoroughly rinse with warm water to remove it. Household bleach can generally be used as an effective cleaner to remove stubborn marks, but care should be taken as some products are considerably stronger than others.

If you have stubborn marks which still can't be removed, view our online Frequently Asked Questions or contact us on 1300 119 119 for further advice.

### Heat Resistance

Caesarstone® is heat resistant, however like all stone materials; Caesarstone® can be damaged by sudden and rapid surface temperature changes. A good rule of thumb is that if your hand cannot tolerate the level of heat of an item to be placed on the surface for more than a few seconds, then the heat source is too high. We always recommend placing hot pots, hot oven trays, frypans, and electrical cooking appliances onto a wooden chopping board or cork mat.

To watch our cleaning instruction video and learn more, visit <https://www.caesarstone.com.au/cleaning-maintenance>

### Tough? Yes. Indestructible? No.

As with any surface, Caesarstone® can be permanently damaged by exposure to strong chemicals and solvents that undermine its physical properties. Do not use products that contain trichlorethane or methylene chloride, such as paint removers or stripper. Avoid all contact with highly aggressive cleaning agents like oven cleaners that have high alkaline/pH levels. Should the surface be accidentally exposed to any of these damaging products, rinse immediately with water to neutralize the effect.

### Do our Concrete and Natural finish designs require extra cleaning?

Caesarstone® Concrete and Natural finish designs carry the same stain and scratch resistance as our polished surfaces, never require sealing and are simple to clean.

However, these two finishes do not disguise marks and fingerprints as well as the polished designs, meaning more regular cleaning may be required using the Caesarstone® Spray Cleaner for daily use and Caesarstone® Cream Cleanser and 3M™ Scotch-Brite™ Non-Scratch Foam Scrub to provide a thorough all over surface clean as per the instructions.





For more design ideas, information and for your nearest showroom, visit our web site:

[www.caesarstone.com.au](http://www.caesarstone.com.au) or call us on 1300 119 119.

©Copyright Caesarstone® 2023. Caesarstone® and other Caesarstone® marks are trademarks of Caesarstone® Ltd and are used under license by Caesarstone® Australia Pty Ltd.

Printed April 2023.

This document supersedes all previous versions and is subject to change without notice. Caesarstone® Australia Pty Ltd ACN 121 819 976